

Sunflame®

Mixer Grinder
CHAMPION



Sunflame®

Sunflame Enterprises Private Limited
58, Sector 27C, Mathura Road,
Faridabad-121 003, Haryana, India

Incase of any suggestion / complaint, please
contact customer care at 1860 330 9999 or
e-mail at customercare@sunflame.com or
write in at the above address.

www.sunflame.com

Instruction Manual



SUNFLAME MIXER GRINDER

For every buyer, the basic demand in a product remains style and performance. Packed with elegance, versatility and performance, the Sunflame mixer grinder is designed to meet the needs of today's fast-paced life. In short, the Sunflame mixer grinder is an important asset for an Indian kitchen.

With the Sunflame mixer grinder, you can look forward to milkshakes, lassi and cold coffee just the way you like them. What's more, the mixer grinder makes light work of wet and dry grinding of masalas, pulses and cereals and pureeing tomatoes, just at the press of a button. Just go through the instructions in this manual carefully and let your mixer grinder delight you with its stunning performance.

Technical Specifications

Model	MG CHAMPION
Voltage	230V AC 50 Hz Single Phase
Protection	2.2 Amp CB
Motor Insulation	Universal Class-B
Power consumption	500 Watts
Rating	30 Min
Motor Speed (Without Load)	20000 RPM (Approx.)
Speed Control	3 Speed Rotary Switch
Material	
Housing	High quality ABS plastic
Liquidiser Jar	J4 Stainless Steel
Grinder Jar	J4 Stainless Steel
Chutney Jar	J4 Stainless Steel
Capacity	
Liquidiser Jar	1.25 ltr
Dry Grinder Jar	1.00 ltr
Chutney Jar	0.35 ltr
Main Cord(PVC)	1.5 mtr.
Plug	2 pin, 6 Amp.

Other Safety Considerations

- To protect against fire, electric shock and personal injury, do not immerse cord, plug or body in water or other liquid.
- Do not operate any appliance with a damaged cord or plug or after the appliance has been damaged in any manner.
- Do not use accessories not recommended by the manufacturers, as there is a danger of fire, electric shock or personal injury.
- Do not place on or near a hot gas or electric burner or in a heated oven .

Children

- Do not allow children to use this Mixer Grinder. Children are vulnerable in the kitchen, particularly when unsupervised and if appliances are being used or cooking is being carried out .
- Teach children to be aware of dangers in the kitchen, warn them of the dangers of reaching up to areas where they cannot see properly or should not be reaching .

Mains Lead

- The mains lead should reach without straining the connections.
- Do not let the mains lead hangover the edge of a worktop where a child could reach it .
- Do not let the lead run across an open space e.g between a low socket and table .
- Do not let the lead run across a cooker or toaster or other hot area, which might damage the cable .

Electrical Requirements

- Check that the voltage on the rating plate of your appliance corresponds with your house electricity supply, which must be A.C. .
- If the socket outlets in your home are not suitable for the plug supplied with this appliance, the plug should be removed and the appropriate one fitted.

Overload Protector

- The Mixer Grinder is protected against the sudden overloads. In case such a situation occurs, then your mixer grinder will automatically turn off.
- To restart the unit, please wait for 2-3 minutes to allow the motor to cool down and also remove the cause of overload. Press the button located at the bottom of the mixer grinder to restart the unit.

HOW TO OPERATE AND CLEAN YOUR SUNFLAME MIXER GRINDER

How to fit the jars

Hold the jar and check if the blade moves freely and rotates. Place the ingredients in the jar. Cover the jar with lid. Place the jar on the basic unit and then turn it clockwise to lock it in the top socket. Plug in. Support lid gently by hand and switch on using the slowest speed and then move on to a higher speed as per requirements. Switch off after operation. For unlocking the jar, turn it anti-clockwise.

How to use blending jar

- This jar can be used for grinding items like soaked rice and dal batter, liquidizing for fruit juices, soups, cocktail, milkshakes, purees etc. The minimum capacity is 1/3 of the jar.
- Fill the jar with the solids to be liquidized such as tomatoes.
- Fit the jar on the main unit.
- Place the lid on the jar.
- If needed, more water can be added. Now switch on the mixer for one minute and you will get finely blended juices and purees.
- If ingredients need to be stirred during wet grinding of rice and dal batter, stop mixer, insert spatula and stir.

How to use dry grinding jar

- This jar can be used for grinding black pepper, roasted coffee seeds, turmeric, coriander, red chillies etc. The jar should not be filled more than ½ of the total capacity.
- Ensure that the jar is absolutely clean and dry.
- Fill the jar with ingredients. Place the lid on the jar and fit the jar on the main unit.
- Grind at low speed for 15 seconds and move to higher speeds.
- For turmeric, first break it into smaller pieces before starting to grind.

How to use chutney jar

- This jar can be used to grind small quantities of dhania, coconut, green chillies, etc. and chutney. The jar must be filled up to the blade level. The jar should not be filled more than ½ of its capacity.
- Put the ingredients into the chutney jar.
- Add a small quantity of water during chutney grinding.

- Put the lid on the top of the jar and fit the jar into the main unit.
- Stir the ingredients if necessary during grinding.
- The ingredients to be grind should not be too large. Cut / break ingredients into small pieces.

Cleaning of the jar

- Pour a little soap and water into the jar, close the lid and run it on the main unit at 1st position. This dislodges the food particles lodged inside the jar.
- Remove the jar and pour out the soap solution and rinse with tap water.
- Wipe the area along the blades with wet cloth and then dry.
- Wipe the body with a wet cloth and then dry.

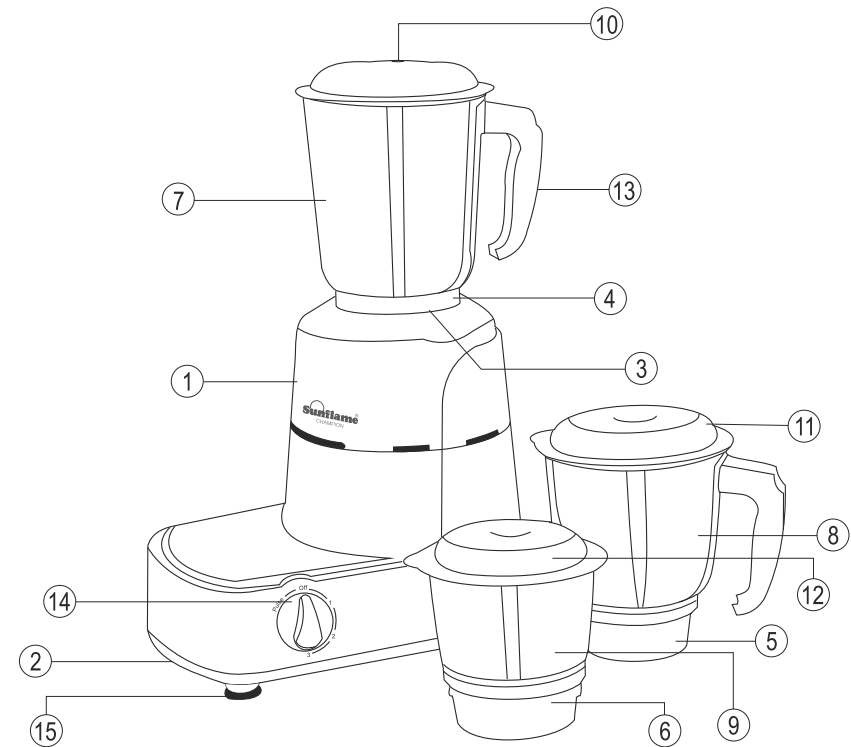

A CHECK LIST FOR YOUR MIXER GRINDER

After unpacking your Sunflame Mixer Grinder, go through the following checklist to familiarize yourself with all the parts.

- | | |
|------------------------------------|--------------------------------|
| 1. Body | 9. Stainless Steel Chutney Jar |
| 2. Bottom | 10. Blender Jar Lid |
| 3. Top Socket | 11. Dry Grinder Jar Lid |
| 4. Blender Socket | 12. Chutney Jar Lid |
| 5. Dry Grinder Socket | 13. Blender Jar Handle |
| 6. Chutney Jar Socket | 14. Switch Knob |
| 7. Stainless Steel Blender Jar | 15. Bottom Pads |
| 8. Stainless Steel Dry Grinder Jar | |

SAFETY PRECAUTIONS FOR YOUR SUNFLAME MIXER GRINDER

The use of any electrical appliances requires the following basic safety rules:

- Always unplug the machine from the power outlet before putting on or removing the blades and before cleaning.
- Never touch the moving parts, blades or disc. Keep hands, hair, clothing, spatula and other utensils away from the Sunflame Mixer Grinder during operation, to avoid personal injury or damage to the machine.
- Fit the blade assembly on the shaft of the large jar only after it is properly attached onto the basic unit. Always fix and remove blades with the help of the spatula.
- Do not use your Sunflame Mixer Grinder without lids in place, over the jars.
- Do not use your Mixer Grinder on wet surfaces, to prevent electrical hazards.
- Do not try to attach or remove the jar while the motor is running.
- Supervise your Sunflame Mixer Grinder closely while in use. Do not leave it alone while in operation.
- Do not run the Sunflame Mixer Grinder without any load.
- Never place any cloth or plastic sheet under the basic unit, as it may get sucked up and block the ventilation holes in the base, during operation.
- Never use attachments that are not recommended by Sunflame.
- Never wash or immerse that basic unit in water.
- The motor rating is for 30 minutes continuous operation. If you need to run it for a longer time, please give 5-10 minutes rest to the machine.
- The grinder jar may heat up during dry grinding due to friction (it has nothing to do with the motor). Let it cool for a few seconds and then remove.

The Sunflame Mixer Grinder carries 2 Years Warranty from the date of original purchase against manufacturing defects. The warranty shall be subject to the following.

Terms and Conditions:

- ❖ Any defective appliance or part thereof will be repaired within the above stated warranty period on receipt of the same with this card duly filled in and stamped by the dealer from whom the appliance is bought to our nearest service center, freight paid and packed securely.
- ❖ In the event of repairs / replacement of any part of the appliance, this warranty will thereafter continue and remain in force only for the unexpired period of the warranty.
- ❖ This warranty is valid only when:-
 - The appliance has been purchased from the company's Authorised Dealer and is accompanied by this warranty card / cash memo.
 - The warranty card is filled up completely and correct information is provided.
 - The appliance has not been opened / tampered / repaired by any one other than our Authorized Service Personnel.
 - The appliance has been installed, used and maintained in accordance with the instruction manual.
- ❖ This warranty does not apply to:
 - Normal wear and tear of the parts.
 - Damage due to chipping, peeling, plating and denting.
 - Damage arising due to running of the appliance on alternate sources of power such as Inverter, Generator or any such auxiliary power supply aid resulting in variation / fluctuating voltage.
 - Breakage or damage to components made of ABS, SAN, bakelite, glass and such plastic / rubber parts, cord, bulbs and surface coating.

- Damages resulting from accidents, mishandling or negligence on the part of the customer.
- Products if used for commercial purposes.
- Products, the serial number of which has been removed, obliterated or altered on the name plate.

❖ This warranty is in lieu of all other warranties, expressed or implied and does not cover indirect or consequential damages / loss

This warranty is restricted at the company's option to repair or to replace the parts proven to have any manufacturing defects and does not cover the replacement of the product. This warranty does not cover any further warranty or guarantee, statutory or otherwise and any remote, indirect or consequential loss, injury or damage. The company's liability under this warranty shall in no event and under no circumstances, exceed the price paid by the customer for the product.

If a customer wishes to lodge a complaint, he should lodge with the concerned dealer or the nearest company service centre along-with the applicable Warranty Card and Cash Memo. The product should be brought to and taken from the service centre at the customer's cost and risk.

All disputes shall be subject to the jurisdiction of Delhi courts only.